

03003/2&1 BECE

June 2024

MATHEMATICS 2&1

Essay and Objective

2 hours

2 & 1

THE WEST AFRICAN EXAMINATIONS COUNCIL

GHANA

Basic Education Certificate Examination

June 2024

MATHEMATICS 2 & 1

2 hours

Essay and Objective

*Do not open this booklet until you are told to do so. While you are waiting, read and observe the following instructions. Write your **name** and **index number** in the spaces provided above.*

This booklet consists of two papers. Answer Paper 2 which comes first, in your answer booklet and Paper 1 on your Objective Test answer sheet. Paper 2 will last 1 hour after which the answer booklet will be collected. Do not start Paper 1 until you are told to do so. Paper 1 will last 1 hour.

*The use of calculators is **not** allowed.*

Answer four questions only.

All questions carry equal marks.

All working must be clearly shown. Marks will not be awarded for correct answers without corresponding working.

1. (a) A fair die and a fair coin are thrown together **once**.
 (i) Write down the set of all possible outcomes.
 (ii) Find the probability of obtaining a prime number and a tail.
- (b) The map of a field is drawn to a scale of 1 : 100. If the width and area of the field on the map are 8 cm and 88 cm² respectively, find in m², the area of the actual field.
- (c) Copy and complete the 3 × 3 magic square such that the sum of the numbers in each row, column and diagonal is equal to 21.

10	3	
	7	

2. (a) Given the vectors $\mathbf{p} = \begin{pmatrix} m+3 \\ 2-n \end{pmatrix}$, $\mathbf{q} = \begin{pmatrix} 3m-1 \\ n-8 \end{pmatrix}$ and $\mathbf{p} = \mathbf{q}$,
 find the values of m and n .
- (b) A man shared an amount of money between his children Baaba and William in the ratio 6 : 5. Baaba received GH¢1,200.00.
 (i) Find the total amount shared.
 (ii) William invested his share in an account at the rate of 20 % simple interest per annum for 2 years. Find the total amount in his account at the end of the 2 years.
3. (a) Simplify: $3\sqrt{50} + 2\sqrt{45} - \sqrt{2} + \sqrt{5}$.
- (b) A wire of length 38 cm is bent into the shape of a rectangle whose length is 7 cm **more than** the width. Find the area of the rectangle.
- (c) If 15 % of the length of a rope is 720 metres, find half of the length of the rope.

4. (a) Using a ruler and a pair of compasses ³ only, construct $\triangle PQR$ such that angle $PQR = 90^\circ$, $|PQ| = 5.5$ cm and $|QR| = 8$ cm.
- (b) Construct a perpendicular of PR from Q .
- (c) Locate M , the intersection of the perpendicular and PR .
- (d) Measure :
 (i) $|MR|$;
 (ii) $|QM|$.
- (e) Calculate, correct to the nearest whole number, the area of triangle QMR .

5.

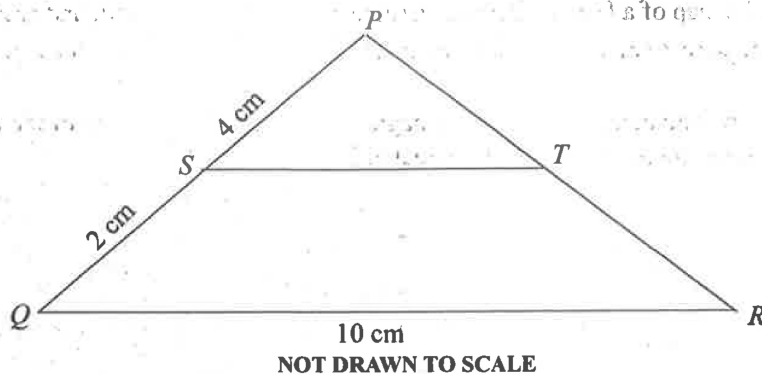

- (a) In the diagram, $\triangle PQR$ is an enlargement of $\triangle PST$. $|PS| = 4$ cm, $|QS| = 2$ cm and $|QR| = 10$ cm.
 (i) Find the length of ST .
 (ii) If $|PQ| = |PR|$, find the area of $\triangle PQR$.
- (b) The total area of a school compound is $900 \frac{1}{2} \text{ m}^2$. The school has Administration and Classroom block, Library, School Park, Roads and Walkways. The areas of the Administration and Classroom block, Library and School Park are $300 \frac{1}{4} \text{ m}^2$, $200 \frac{1}{2} \text{ m}^2$, and $120 \frac{1}{8} \text{ m}^2$ respectively. Find the area covered by Roads and Walkways altogether.
6. (a) Copy and complete the table for the relation $F = \frac{9}{5}C + 32$.
 where F and C are degrees Fahrenheit and degrees Celsius respectively.
- | | | | | | | | |
|------------------|----|---|----|----|----|----|----|
| $^\circ\text{C}$ | 0 | 5 | 10 | 15 | 20 | 25 | 30 |
| $^\circ\text{F}$ | 32 | | | | 68 | | |
- (b) Using a scale of 2 cm to 10 units on the vertical axis ($^\circ\text{F}$) and 2 cm to 5 units on the horizontal axis ($^\circ\text{C}$), draw a linear graph for the relation.
- (c) Use the graph to find the temperature in degrees celsius when $F = 55$ degrees.
- (d) Interpret the slope of the relation.

END OF ESSAY TEST

Turn over

BLANK PAGE

DO NOT TURN OVER THIS PAGE UNTIL YOU ARE TOLD TO DO SO.

**YOU WILL BE PENALIZED SEVERELY IF YOU ARE
FOUND LOOKING AT THE NEXT PAGE BEFORE
YOU ARE TOLD TO DO SO.**

PAPER 1
OBJECTIVE TEST

1 hour

Answer all the questions on your Objective Test answer sheet.

1. Use **2B** pencil throughout.
2. On the pre-printed answer sheet, check that the following details are **correctly** printed: Your **surname** followed by your **other names**, the *Subject Name*, your *Index Number*, *Centre Number* and the *Paper Code*.
3. In the boxes marked *Candidate Number*, *Centre Number* and *Paper Code*, **reshade** each of the shaded spaces.
4. An example is given below. This is for a female candidate whose name is Erica Afiba MANU. Her *index number* is 772384188 and she is writing the examination at *Centre Number* 77234. She is offering *Mathematics 1* and the *Paper Code* is 0301.

THE WEST AFRICAN EXAMINATIONS COUNCIL, GHANA BASIC EDUCATION CERTIFICATE EXAMINATION OBJECTIVE ANSWER SHEET

CANDIDATE NAME: MANU ERICA AFIBA	SUBJECT NAME: MATHEMATICS 1
--	---------------------------------------

- | | |
|--|---|
| <ol style="list-style-type: none"> 1. Use 2B pencil. Press firmly. 2. Answer each question by choosing one letter and then, shade through the letter chosen like this <input type="checkbox"/>A <input checked="" type="checkbox"/>B <input type="checkbox"/>C <input type="checkbox"/>D <input type="checkbox"/>E 3. If you want to change an answer, erase your first mark completely. | <ol style="list-style-type: none"> 4. If only four alternative answers are given for each question, ignore the letter E. 5. Your question paper may have fewer than 60 questions. |
|--|---|

CANDIDATE NUMBER	CENTRE NUMBER	PAPER CODE	
7 7 2 3 8 4 1 8 8	7 7 2 3 4	0 3 0 1	For Supervisors only. If candidate is absent shade this space. <input type="checkbox"/>
<input type="checkbox"/> 0 <input type="checkbox"/> 0 <input type="checkbox"/> 0 <input type="checkbox"/> 0 <input type="checkbox"/> 0 <input type="checkbox"/> 0 <input type="checkbox"/> 0 <input type="checkbox"/> 0 <input type="checkbox"/> 0	<input type="checkbox"/> 0 <input type="checkbox"/> 0 <input type="checkbox"/> 0 <input type="checkbox"/> 0 <input type="checkbox"/> 0	<input type="checkbox"/> 0 <input type="checkbox"/> 0 <input type="checkbox"/> 0 <input type="checkbox"/> 0	
<input type="checkbox"/> 1 <input type="checkbox"/> 1 <input type="checkbox"/> 1 <input type="checkbox"/> 1 <input type="checkbox"/> 1 <input type="checkbox"/> 1 <input checked="" type="checkbox"/> 1 <input type="checkbox"/> 1 <input type="checkbox"/> 1	<input type="checkbox"/> 1 <input type="checkbox"/> 1 <input type="checkbox"/> 1 <input type="checkbox"/> 1 <input type="checkbox"/> 1	<input type="checkbox"/> 1 <input type="checkbox"/> 1 <input type="checkbox"/> 1 <input type="checkbox"/> 1	
<input type="checkbox"/> 2 <input type="checkbox"/> 2 <input checked="" type="checkbox"/> 2 <input type="checkbox"/> 2 <input type="checkbox"/> 2 <input type="checkbox"/> 2 <input type="checkbox"/> 2 <input type="checkbox"/> 2 <input type="checkbox"/> 2	<input type="checkbox"/> 2 <input type="checkbox"/> 2 <input checked="" type="checkbox"/> 2 <input type="checkbox"/> 2	<input type="checkbox"/> 2 <input type="checkbox"/> 2 <input type="checkbox"/> 2 <input type="checkbox"/> 2	
<input type="checkbox"/> 3 <input type="checkbox"/> 3 <input type="checkbox"/> 3 <input checked="" type="checkbox"/> 3 <input type="checkbox"/> 3 <input type="checkbox"/> 3 <input type="checkbox"/> 3 <input type="checkbox"/> 3 <input type="checkbox"/> 3	<input type="checkbox"/> 3 <input type="checkbox"/> 3 <input type="checkbox"/> 3 <input checked="" type="checkbox"/> 3	<input type="checkbox"/> 3 <input checked="" type="checkbox"/> 3 <input type="checkbox"/> 3 <input type="checkbox"/> 3	
<input type="checkbox"/> 4 <input type="checkbox"/> 4 <input type="checkbox"/> 4 <input type="checkbox"/> 4 <input checked="" type="checkbox"/> 4 <input type="checkbox"/> 4 <input type="checkbox"/> 4 <input type="checkbox"/> 4 <input type="checkbox"/> 4	<input type="checkbox"/> 4 <input type="checkbox"/> 4 <input type="checkbox"/> 4 <input type="checkbox"/> 4 <input checked="" type="checkbox"/> 4	<input type="checkbox"/> 4 <input type="checkbox"/> 4 <input type="checkbox"/> 4 <input type="checkbox"/> 4	
<input type="checkbox"/> 5 <input type="checkbox"/> 5 <input type="checkbox"/> 5 <input type="checkbox"/> 5 <input type="checkbox"/> 5 <input type="checkbox"/> 5 <input type="checkbox"/> 5 <input type="checkbox"/> 5 <input type="checkbox"/> 5	<input type="checkbox"/> 5 <input type="checkbox"/> 5 <input type="checkbox"/> 5 <input type="checkbox"/> 5 <input type="checkbox"/> 5	<input type="checkbox"/> 5 <input type="checkbox"/> 5 <input type="checkbox"/> 5 <input type="checkbox"/> 5	
<input type="checkbox"/> 6 <input type="checkbox"/> 6 <input type="checkbox"/> 6 <input type="checkbox"/> 6 <input type="checkbox"/> 6 <input type="checkbox"/> 6 <input type="checkbox"/> 6 <input type="checkbox"/> 6 <input type="checkbox"/> 6	<input type="checkbox"/> 6 <input type="checkbox"/> 6 <input type="checkbox"/> 6 <input type="checkbox"/> 6 <input type="checkbox"/> 6	<input type="checkbox"/> 6 <input type="checkbox"/> 6 <input type="checkbox"/> 6 <input type="checkbox"/> 6	
<input checked="" type="checkbox"/> 7 <input checked="" type="checkbox"/> 7 <input type="checkbox"/> 7 <input type="checkbox"/> 7 <input type="checkbox"/> 7 <input type="checkbox"/> 7 <input type="checkbox"/> 7 <input type="checkbox"/> 7 <input type="checkbox"/> 7	<input checked="" type="checkbox"/> 7 <input checked="" type="checkbox"/> 7 <input type="checkbox"/> 7 <input type="checkbox"/> 7	<input type="checkbox"/> 7 <input type="checkbox"/> 7 <input type="checkbox"/> 7 <input type="checkbox"/> 7	
<input type="checkbox"/> 8 <input type="checkbox"/> 8 <input type="checkbox"/> 8 <input type="checkbox"/> 8 <input checked="" type="checkbox"/> 8 <input type="checkbox"/> 8 <input type="checkbox"/> 8 <input checked="" type="checkbox"/> 8 <input type="checkbox"/> 8	<input type="checkbox"/> 8 <input type="checkbox"/> 8 <input type="checkbox"/> 8 <input type="checkbox"/> 8 <input type="checkbox"/> 8	<input type="checkbox"/> 8 <input type="checkbox"/> 8 <input type="checkbox"/> 8 <input type="checkbox"/> 8	
<input type="checkbox"/> 9 <input type="checkbox"/> 9 <input type="checkbox"/> 9 <input type="checkbox"/> 9 <input type="checkbox"/> 9 <input type="checkbox"/> 9 <input type="checkbox"/> 9 <input type="checkbox"/> 9 <input type="checkbox"/> 9	<input type="checkbox"/> 9 <input type="checkbox"/> 9 <input type="checkbox"/> 9 <input type="checkbox"/> 9 <input type="checkbox"/> 9	<input type="checkbox"/> 9 <input type="checkbox"/> 9 <input type="checkbox"/> 9 <input type="checkbox"/> 9	

Answer all questions.

Each question is followed by four options lettered A to D. Find the correct option for each question and shade in pencil on your answer sheet the answer space which bears the same letter as the option you have chosen. Give only one answer to each question. An example is given below.

If $3n + 2 = 8$, find the value of n .

- A. 10
- B. 6
- C. 3
- D. 2

The correct answer is 2, which is lettered D and therefore answer space D would be shaded.

A B C D

Think carefully before you shade the answer spaces. Erase completely any answers you wish to change.

Do all rough work on this question paper.

Now answer the following questions.

1. Two brands of airconditioners S and T cost GH¢ 3,000.00 and GH¢ 4,000.00 respectively. A company budgeted GH¢ 20,000.00 to buy airconditioners. If the company bought 5 units of brand S instead of brand T , how much did it save?
 - A. GH¢ 1,000.00
 - B. GH¢ 5,000.00
 - C. GH¢ 20,000.00
 - D. GH¢ 15,000.00

2. Zalia and Amina shared an amount of money in the ratio 2 : 5. If Amina had GH¢ 150.00 more than Zalia, how much did they share?
 - A. GH¢ 100.00
 - B. GH¢ 250.00
 - C. GH¢ 450.00
 - D. GH¢ 350.00

3. Which of the following is an example of quantitative data?
 - A. Colour
 - B. Gender
 - C. Marital status
 - D. Length

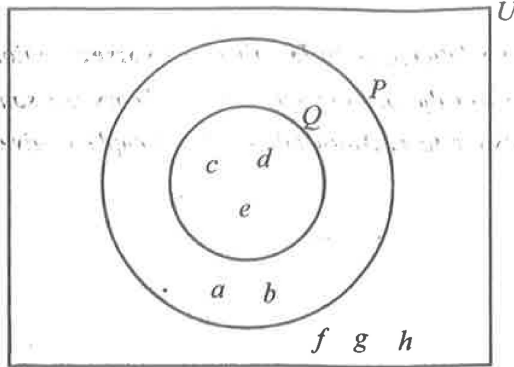

In the diagram, P and Q are two sets and U is the universal set.

Use the information to answer questions 4 and 5.

4. Find $P \cap Q$.
- $\{c, d, e\}$
 - $\{a, b\}$
 - $\{a, b, c, d, e\}$
 - $\{f, g, h\}$
5. How many members are in set Q ?
- 2
 - 3
 - 8
 - 5
6. Amadu walked to a point such that he is **always** the same distance from two villages P and Q . Which of the following **best** describes the locus of Amadu?
- An arc passing through line PQ
 - A circle passing through line PQ
 - Straight line PQ
 - Perpendicular bisector of line PQ
7. A bag of rice weighs 2 kg. If the empty bag weighs 150 g, find the weight of the rice.
[1 kg = 1,000 g]
- 0.175 kg
 - 0.185 kg
 - 1.850 kg
 - 1.750 kg
8. Andrews drew three lines such that the length of the first one is 10 cm, the second is 15 cm longer than the first one and the third is 9 cm less than the second. Find the length of the third line.
- 4 cm
 - 14 cm
 - 34 cm
 - 16 cm

Turn over

9. Find the truth set of $2x - 4 < 6 + 3x$.
- A. $\{x : x < 2\}$
 B. $\{x : x > -2\}$
 C. $\{x : x > -10\}$
 D. $\{x : x < 10\}$
10. The locus of points equidistant from a fixed point is called a
- A. chord.
 B. circle.
 C. mediator.
 D. diameter.
11. Evaluate: $\sqrt{75} + \sqrt{18} - \sqrt{27}$.
- A. $2\sqrt{3} - 3\sqrt{2}$
 B. $2\sqrt{3} + 3\sqrt{2}$
 C. $\sqrt{6}$
 D. $5\sqrt{6}$

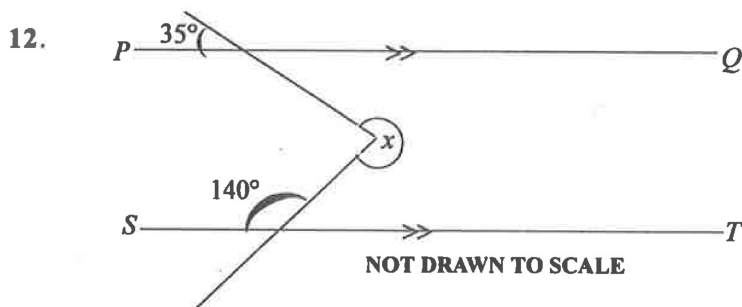

In the diagram, line PQ is parallel to line ST . Find the value of the angle marked x .

- A. 140°
 B. 220°
 C. 290°
 D. 285°
13. A hawker is carrying a basket load of three types of fruits: oranges, mangoes and pears.
- If $\frac{2}{5}$ of the fruits are oranges and $\frac{6}{25}$ mangoes, what percentage of the fruits are pears?
- A. 9 %
 B. 18 %
 C. 64 %
 D. 36 %

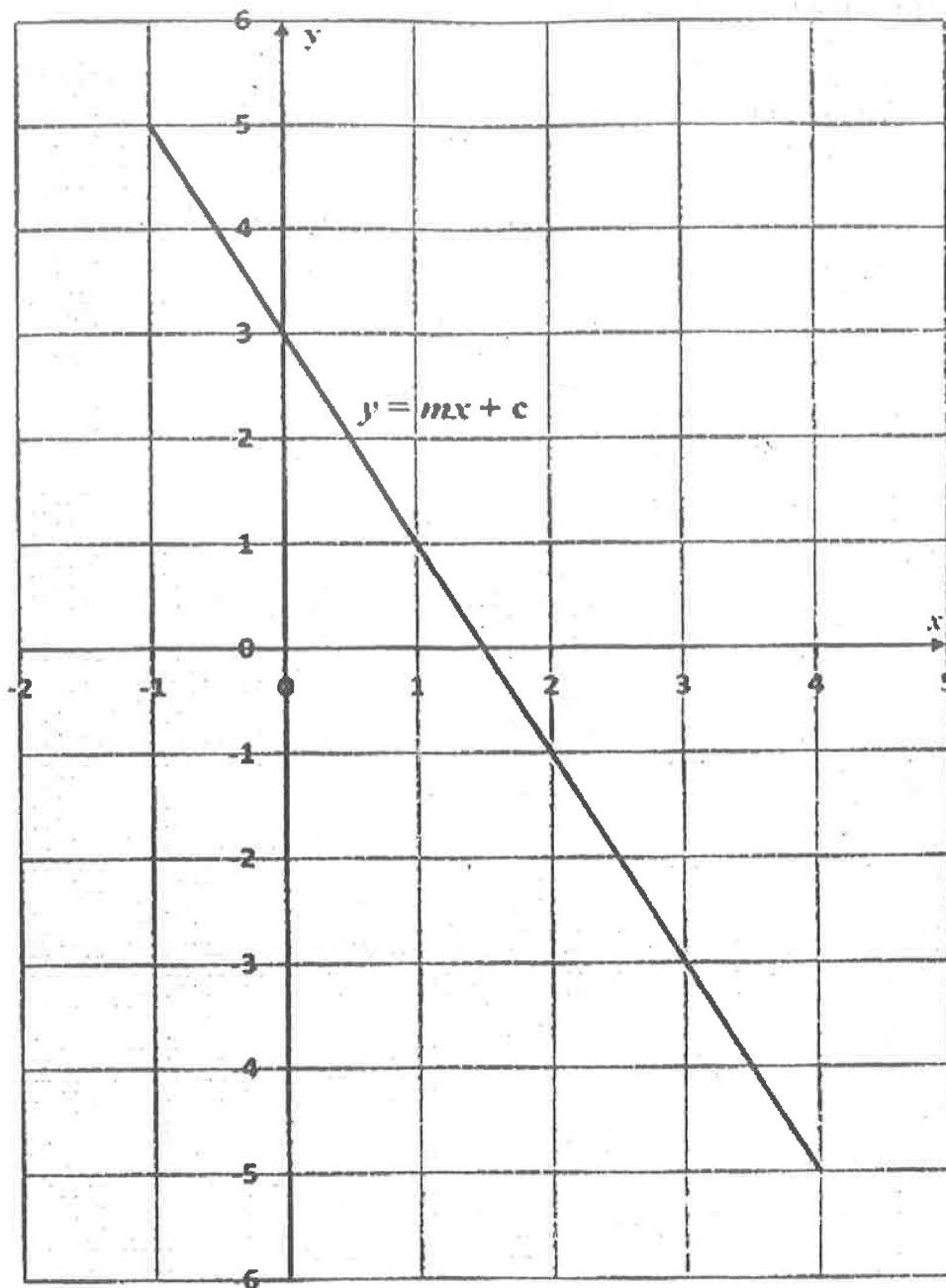

The diagram shows the graph of a linear relation of the form $y = mx + c$.
Use the graph to answer questions 14 and 15.

14. Find the slope of the relation.
- A. -2
 - B. -1
 - C. 2
 - D. 1
15. Find the equation of the relation.
- A. $y = -2x + 3$
 - B. $y = -2x + 2$
 - C. $y = 2x + 3$
 - D. $y = 2x - 3$

16. Araba is 3 years younger than her sister. If the sum of their ages is 17 years, find Araba's age.
- A. 7 years
B. 8 years
C. 10 years
D. 9 years
17. A number of oranges are shared among 50 students and each got 15 oranges. If the same number of oranges are shared equally among 30 students, how many will each student get?
- A. 13
B. 15
C. 25
D. 20
18. If the bearing of Q from P is 120° , find the bearing of P from Q .
- A. 060°
B. 210°
C. 300°
D. 240°
19. Given the vectors $\mathbf{m} = \begin{pmatrix} 5 \\ -1 \end{pmatrix}$ and $\mathbf{n} = \begin{pmatrix} -4 \\ 2 \end{pmatrix}$, find $2\mathbf{m} + \mathbf{n}$.
- A. $\begin{pmatrix} 6 \\ 0 \end{pmatrix}$
B. $\begin{pmatrix} -6 \\ 0 \end{pmatrix}$
C. $\begin{pmatrix} 0 \\ 6 \end{pmatrix}$
D. $\begin{pmatrix} 0 \\ -6 \end{pmatrix}$
20. Simplify: $\frac{27^{m+1}}{3^{m+2}}$.
- A. 3^{2m}
B. 3^{2m-1}
C. 3^{2m+2}
D. 3^{2m+1}
21. There are 15 white and 25 black identical balls in a box. If a ball is selected at random from the box, find the probability that it is white.
- A. $\frac{1}{25}$
B. $\frac{1}{15}$
C. $\frac{3}{8}$
D. $\frac{5}{8}$

22. The area of a rectangle is 18 cm^2 . If the width is 2 cm, find its perimeter.
- 18 cm
 - 20 cm
 - 36 cm
 - 22 cm
23. Find the interest on GH¢ 400.00 for 2 years at 10 % simple interest per annum.
- GH¢ 8.00
 - GH¢ 40.00
 - GH¢ 80.00
 - GH¢ 60.00
24. One of the factors of the expression $4m^2 + 12m - 8m - 24$ is $(4m - 8)$. Find the other factor.
- $m - 3$
 - $m + 3$
 - $2m + 3$
 - $2m - 3$
25. An article which cost GH¢ 600.00 was sold at a discount of 10 %. Find the selling price.
- GH¢ 60.00
 - GH¢ 504.00
 - GH¢ 560.00
 - GH¢ 540.00
26. Make m the subject of the relation $\frac{1}{m} = \frac{1}{p} + \frac{1}{r}$.
- $m = \frac{pr}{r + p}$
 - $m = \frac{pr}{r - p}$
 - $m = \frac{r - p}{pr}$
 - $m = \frac{r + p}{pr}$
27. The point $P(-2, 3)$ is translated by a vector $\begin{pmatrix} -1 \\ 3 \end{pmatrix}$ to a point R . Find the coordinates of R .
- $(6, -2)$
 - $(-3, 6)$
 - $(-3, -6)$
 - $(-1, 0)$

Turn over

28. A frog leaps in such a way that its distance, in metres, from its starting position after **each** leap is given by 4, 7, 10,
Find its distance from the starting position after the 10th leap.
- A. 28
B. 31
C. 37
D. 34
29. A bus departed from Elmina at 9:15 pm and arrived in Accra at 2:45 am the next day.
How long did the journey take?
- A. 4 hours 20 minutes
B. 4 hours 30 minutes
C. 5 hours 30 minutes
D. 5 hours 20 minutes
30. Simplify: $3x - 2(3 + 2x) + x(2x + 4)$.
- A. $2x^2 + 11x - 6$
B. $2x^2 + 3x - 6$
C. $2x^2 - 4x - 6$
D. $2x^2 + 4x - 6$

31.

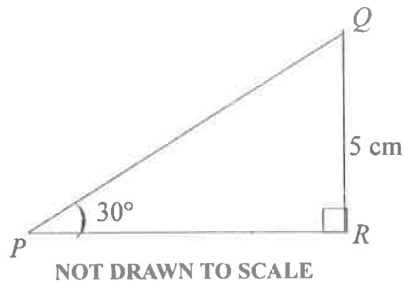

In the diagram, $\angle QPR = 30^\circ$ and $|QR| = 5$ cm.
[Take $\sin 30^\circ = \frac{1}{2}$].

Find the length of \overline{PQ} .

- A. 2.5 cm
B. 5.0 cm
C. 12.0 cm
D. 10.0 cm
32. A fair coin and a fair die are rolled together **once**. Find the probability of obtaining a tail and an odd number.
- A. $\frac{1}{4}$
B. $\frac{1}{3}$
C. $\frac{2}{3}$
D. $\frac{1}{2}$

33. If the gradient of a straight line is zero, then the line
- A. is vertical.
 - B. is horizontal.
 - C. falls to the right.
 - D. rises to the right.
34. Madam Nancy wants to know which of the teachers in her school is liked best by most of the students. Which of the following methods is **most suitable** for collecting the data?
- A. Experiment
 - B. Database
 - C. Questionnaire
 - D. Observation
35. Mansah packed 1,800 apples into a number of boxes. If **each** box contained 120 apples, how many boxes were fully packed?
- A. 15
 - B. 16
 - C. 18
 - D. 17
36. The cost of three items at a shop are GH¢ 72.00, GH¢ 1,105.00 and GH¢216.00. If a customer bought all the three items and received a change of GH¢ 107.00, how much did he initially give the shopkeeper?
- A. GH¢1,300.00
 - B. GH¢1,400.00
 - C. GH¢2,000.00
 - D. GH¢1,500.00

<i>Number on die</i>	1	2	3	4	5	6
<i>Frequency</i>	4	3	3	2	3	5

The table shows the results when a student tossed a die many times.
Use the information to answer questions 37 and 38.

37. Find the mode.
- A. 6
 - B. 5
 - C. 3
 - D. 4
38. How many times did the student throw the die?
- A. 6
 - B. 18
 - C. 21
 - D. 20

39. Find the image of the point $(-3, 5)$ when it is rotated through 360° about the origin.
- A. $(5, -3)$
 - B. $(-3, 5)$
 - C. $(-5, 3)$
 - D. $(-3, -5)$
40. A story book contains 50 pages. If a student reads 10 pages per hour, find the relationship between the number of **unread** pages (N) and time (t).
- A. $N = 10t + 50$
 - B. $N = -10t + 50$
 - C. $N = -\frac{1}{10}t + 50$
 - D. $N = 10t - 50$

END OF PAPER