

03006/2&1 BECE  
June 2022  
MATHEMATICS 2&1  
Essay and Objective  
2 hours

**2 & 1**

**THE WEST AFRICAN EXAMINATIONS COUNCIL  
GHANA**

**Basic Education Certificate Examination**

June 2022

**MATHEMATICS 2 & 1**  
Essay and Objective

2 hours

*Do not open this booklet until you are told to do so. While you are waiting, read and observe the following instructions. Write your **name and index number** in the spaces provided above.*

*This booklet consists of two papers. Answer Paper 2 which comes first, in your answer booklet and Paper 1 on your Objective Test answer sheet. Paper 2 will last 1 hour after which the answer booklet will be collected. Do **not** start Paper 1 until you are told to do so. Paper 1 will last 1 hour.*

*The use of calculators is **not** allowed.*

Essay

Answer four questions only.

All questions carry equal marks.

All working must be clearly shown. Marks will not be awarded for correct answers without corresponding working.

1. (a) Given that  $P = \{\text{factors of } 36\}$  and  $Q = \{\text{factors of } 54\}$ ,
- list the members in the sets  $P$  and  $Q$ .
  - Find:
    - $P \cap Q$ ;
    - $n(P \cap Q)$ ;
    - the Highest Common Factor (HCF) of 36 and 54.

(b) Write down the next two terms of the sequence 1, 4, 9, . . . , . . .

(c) The median of the ordered set of observations 2, 3,  $(4m - 3)$ ,  $(3m + 1)$ , 11 and 13 in ascending order is 6. Find the value of  $m$ .

2. (a) Simplify:  $(\frac{1}{3} + \frac{1}{12}) \div (\frac{2}{3} - \frac{5}{8})$ .

(b) Find the product of  $(2x - 3)$  and  $(2x + 3)$ .

(c)

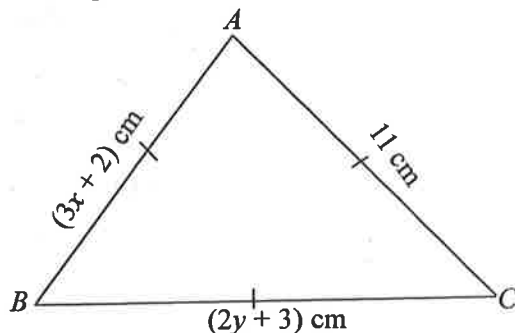

NOT DRAWN TO SCALE

In the diagram,  $ABC$  is an equilateral triangle. Find the value of  $(x + y)$ .

3. (a) Given the relation  $L = \frac{2(m^2 - n^2)}{4(m + n)}$ :

- simplify  $L$ ;
- find the value of  $L$  when  $m = 2$  and  $n = 3$ .

(b) Solve  $\frac{4}{3x} = 7 - \frac{3}{x}$ .

(c) A salesman gets a commission of  $5\frac{1}{2}\%$  of the value of items he sells. The salesman sells 12 textbooks at GH¢ 25.00 per book, 3 scientific calculators at GH¢ 50.00 per calculator and 8 packets of bic pens at GH¢ 50.00 per packet. Calculate the salesman's commission.

4. (a) Fred is  $(x - 1)$  years old now. How old:  
 (i) was he 4 years ago?  
 (ii) will he be 8 years from now?  
 (iii) is he now, if his age in 8 years time will be three times his age 4 years ago?
- (b) The perimeter of a rectangular cocoa farm is 497 km. The length of the farm is  $2\frac{1}{2}$  times the width. Find the:  
 (i) width;  
 (ii) length of the farm.
5. (a) Factorize:  $(x - y)(3m + n) - (x - y)(m - 2n)$ .
- (b) Given that  $\mathbf{p} = \begin{pmatrix} 2 - 3x \\ 5 - 2y \end{pmatrix}$ ,  $\mathbf{q} = \begin{pmatrix} -1 \\ 5 \end{pmatrix}$  and  $\mathbf{p} - \mathbf{q} = \begin{pmatrix} 6 \\ 8 \end{pmatrix}$ , find the value of  $(x + y)$ .
- (c) (i) Find the truth set of  $\frac{x-1}{2} \leq \frac{1}{2} + x$ .  
 (ii) Illustrate the answer in (i) on the number line.
6. (a) Copy and complete the table for the relation  $y = 5 - 2x$  for  $-3 \leq x \leq 4$ .
- |   |    |    |    |   |   |   |   |    |
|---|----|----|----|---|---|---|---|----|
| x | -3 | -2 | -1 | 0 | 1 | 2 | 3 | 4  |
| y | 11 |    |    | 5 |   | 1 |   | -3 |
- (b) Using a scale of 2 cm to 1 unit on  $x$ -axis and 2 cm to 2 units on the  $y$ -axis, draw on a graph sheet two perpendicular axes  $ox$  and  $oy$  for  $-5 \leq x \leq 5$  and  $-12 \leq y \leq 12$ .
- (c) (i) Using the table, plot all the points of the relation  $y = 5 - 2x$ .  
 (ii) Draw a straight line through all the points.
- (d) Using the graph, find the:  
 (i) value of  $y$  when  $x = -2.6$ ;  
 (ii) value of  $x$  when  $y = -2.8$ ;  
 (iii) gradient of the line.

**END OF ESSAY TEST**

12 224  
35

16

***BLANK PAGE***

**DO NOT TURN OVER THIS PAGE  
UNTIL YOU ARE TOLD TO DO SO.**

**YOU WILL BE PENALIZED SEVERELY IF YOU ARE  
FOUND LOOKING AT THE NEXT PAGE BEFORE  
YOU ARE TOLD TO DO SO.**

PAPER 1  
OBJECTIVE TEST

1 hour

*Answer all the questions on your Objective Test answer sheet.*

1. Use **2B** pencil throughout.
2. On the pre-printed answer sheet, check that the following details are **correctly** printed: Your **surname** followed by your **other names**, the *Subject Name*, your *Index Number*, *Centre Number* and the *Paper Code*.
3. In the boxes marked *Candidate Number*, *Centre Number* and *Paper Code*, **reshade** each of the shaded spaces.
4. An example is given below. This is for a female candidate whose name is Dora Afi SULE. Her *index number* is 772384188 and she is writing the examination at *Centre Number* 77234. She is offering *Mathematics 1* and the *Paper Code* is 0301.

**THE WEST AFRICAN EXAMINATIONS COUNCIL, GHANA  
BASIC EDUCATION CERTIFICATE EXAMINATION  
OBJECTIVE ANSWER SHEET**

CANDIDATE NAME: <b>SULE DORA AFI</b>	SUBJECT NAME: <b>MATHEMATICS 1</b>
---	---------------------------------------

1. Use 2B pencil. Press firmly.
2. Answer each question by choosing one letter and then, shade through the letter chosen like this  A  B  C  D  E
3. If you want to change an answer, erase your first mark completely.
4. If only four alternative answers are given for each question, ignore the letter E.
5. Your question paper may have fewer than 60 questions.

CANDIDATE NUMBER								CENTRE NUMBER					PAPER CODE				
7	7	2	3	8	4	1	8	8	7	7	2	3	4	0	3	0	1
<input type="checkbox"/>	<input type="checkbox"/>	<input type="checkbox"/>	<input type="checkbox"/>	<input type="checkbox"/>	<input type="checkbox"/>	<input type="checkbox"/>	<input type="checkbox"/>	<input type="checkbox"/>	<input type="checkbox"/>	<input type="checkbox"/>	<input type="checkbox"/>	<input type="checkbox"/>	<input type="checkbox"/>	<input type="checkbox"/>	<input type="checkbox"/>	<input type="checkbox"/>	<input type="checkbox"/>
<input type="checkbox"/>	<input type="checkbox"/>	<input type="checkbox"/>	<input type="checkbox"/>	<input type="checkbox"/>	<input type="checkbox"/>	<input type="checkbox"/>	<input type="checkbox"/>	<input type="checkbox"/>	<input type="checkbox"/>	<input type="checkbox"/>	<input type="checkbox"/>	<input type="checkbox"/>	<input type="checkbox"/>	<input type="checkbox"/>	<input type="checkbox"/>	<input type="checkbox"/>	<input type="checkbox"/>
<input type="checkbox"/>	<input type="checkbox"/>	<input type="checkbox"/>	<input type="checkbox"/>	<input type="checkbox"/>	<input type="checkbox"/>	<input type="checkbox"/>	<input type="checkbox"/>	<input type="checkbox"/>	<input type="checkbox"/>	<input type="checkbox"/>	<input type="checkbox"/>	<input type="checkbox"/>	<input type="checkbox"/>	<input type="checkbox"/>	<input type="checkbox"/>	<input type="checkbox"/>	<input type="checkbox"/>
<input type="checkbox"/>	<input type="checkbox"/>	<input type="checkbox"/>	<input type="checkbox"/>	<input type="checkbox"/>	<input type="checkbox"/>	<input type="checkbox"/>	<input type="checkbox"/>	<input type="checkbox"/>	<input type="checkbox"/>	<input type="checkbox"/>	<input type="checkbox"/>	<input type="checkbox"/>	<input type="checkbox"/>	<input type="checkbox"/>	<input type="checkbox"/>	<input type="checkbox"/>	<input type="checkbox"/>
<input type="checkbox"/>	<input type="checkbox"/>	<input type="checkbox"/>	<input type="checkbox"/>	<input type="checkbox"/>	<input type="checkbox"/>	<input type="checkbox"/>	<input type="checkbox"/>	<input type="checkbox"/>	<input type="checkbox"/>	<input type="checkbox"/>	<input type="checkbox"/>	<input type="checkbox"/>	<input type="checkbox"/>	<input type="checkbox"/>	<input type="checkbox"/>	<input type="checkbox"/>	<input type="checkbox"/>
<input type="checkbox"/>	<input type="checkbox"/>	<input type="checkbox"/>	<input type="checkbox"/>	<input type="checkbox"/>	<input type="checkbox"/>	<input type="checkbox"/>	<input type="checkbox"/>	<input type="checkbox"/>	<input type="checkbox"/>	<input type="checkbox"/>	<input type="checkbox"/>	<input type="checkbox"/>	<input type="checkbox"/>	<input type="checkbox"/>	<input type="checkbox"/>	<input type="checkbox"/>	<input type="checkbox"/>
<input type="checkbox"/>	<input type="checkbox"/>	<input type="checkbox"/>	<input type="checkbox"/>	<input type="checkbox"/>	<input type="checkbox"/>	<input type="checkbox"/>	<input type="checkbox"/>	<input type="checkbox"/>	<input type="checkbox"/>	<input type="checkbox"/>	<input type="checkbox"/>	<input type="checkbox"/>	<input type="checkbox"/>	<input type="checkbox"/>	<input type="checkbox"/>	<input type="checkbox"/>	<input type="checkbox"/>
<input type="checkbox"/>	<input type="checkbox"/>	<input type="checkbox"/>	<input type="checkbox"/>	<input type="checkbox"/>	<input type="checkbox"/>	<input type="checkbox"/>	<input type="checkbox"/>	<input type="checkbox"/>	<input type="checkbox"/>	<input type="checkbox"/>	<input type="checkbox"/>	<input type="checkbox"/>	<input type="checkbox"/>	<input type="checkbox"/>	<input type="checkbox"/>	<input type="checkbox"/>	<input type="checkbox"/>
<input type="checkbox"/>	<input type="checkbox"/>	<input type="checkbox"/>	<input type="checkbox"/>	<input type="checkbox"/>	<input type="checkbox"/>	<input type="checkbox"/>	<input type="checkbox"/>	<input type="checkbox"/>	<input type="checkbox"/>	<input type="checkbox"/>	<input type="checkbox"/>	<input type="checkbox"/>	<input type="checkbox"/>	<input type="checkbox"/>	<input type="checkbox"/>	<input type="checkbox"/>	<input type="checkbox"/>

For Supervisors only. If candidate is absent shade this space.



Answer all questions.

Each question is followed by four options lettered A to D. Find the correct option for each question and shade in pencil on your answer sheet the answer space which bears the same letter as the option you have chosen. Give only one answer to each question. An example is given below.

If  $3n + 2 = 8$ , find the value of  $n$ .

- A. 10
- B. 6
- C. 3
- D. 2

The correct answer is 2, which is lettered D and therefore answer space D would be shaded.

A  B  C  D

Think carefully before you shade the answer spaces. Erase completely any answers you wish to change.

Do all rough work on this question paper.

Now answer the following questions.

1. If  $x = \frac{b^2 - 4ac}{2a}$ , find  $x$  when  $a = 2$ ,  $b = -4$  and  $c = -2$ .

- A. 0
- B. 4
- C. 8
- D. 16

2. A mother has GH¢ 5.00 and gives each of her 3 children GH¢ 1.50 as pocket money. How much is left for her?

- A. GH¢ 0.15
- B. GH¢ 0.50
- C. GH¢ 3.50
- D. GH¢ 4.50

3. What is the length of the side of a square of area  $225 \text{ cm}^2$ ?

- A. 12.00 cm
- B. 15.00 cm
- C. 56.25 cm
- D. 112.50 cm

4. The volume of a cylinder is  $40\pi \text{ cm}^3$ . If the height of the cylinder is 10 cm, find the base radius.
- A. 1 cm
  - B. 2 cm
  - C. 3 cm
  - D. 4 cm
5. Factorize completely  $xy - xm - my + m^2$ .
- A.  $(x - m)(y - m)$
  - B.  $(m - y)(x - m)$
  - C.  $(y - m)(m - x)$
  - D.  $(m - y)(m - x)$
6. Solve:  $5x - (7x - 3) \leq 9$ .
- A.  $x \leq -3$
  - B.  $x \geq -3$
  - C.  $x \geq -6$
  - D.  $x \leq 3$
7. Express  $\frac{3}{8}$  as a decimal fraction.
- A. 0.375
  - B. 0.429
  - C. 0.365
  - D. 0.625
8. Which of the following is **not** a quadrilateral?
- A. Parallelogram
  - B. Rhombus
  - C. Triangle
  - D. Rectangle

9. A football match starts at 2.20 p.m. and lasts for 1 hour 50 minutes. At what time will the game end?
- A. 3.10 p.m.
  - B. 4.10 p.m.
  - C. 5.10 p.m.
  - D. 6.10 p.m.
10. Expand:  $(2a - b)(a - b)$ .
- A.  $2a^2 + 3ab + b$
  - B.  $2a^2 - 3ab + b^2$
  - C.  $2a^2 - 3ab - b^2$
  - D.  $2a^2 + 3ab - b$
11. Which of the following is the **largest** set?
- A. {Composite}
  - B. {Integers}
  - C. {Natural numbers}
  - D. {Whole numbers}
12. Adwoa travelled 12 km due north and 5 km due east. How far was she from her starting point?
- A. 7 km
  - B. 13 km
  - C. 17 km
  - D. 60 km
13. Write 1930.54 in standard form.
- A.  $1.93054 \times 10^3$
  - B.  $1.93054 \times 10^2$
  - C.  $1.93054 \times 10^{-2}$
  - D.  $1.93054 \times 10^{-3}$

14. Solve:  $(x - 1) = \frac{1}{2}(x + 2)$ .

A. 0

B.  $1\frac{1}{3}$

C.  $1\frac{1}{2}$

D. 4

15. A car travels 36 kilometres in an hour. Find its speed in metres per second.

A.  $10 \text{ m s}^{-1}$

B.  $20 \text{ m s}^{-1}$

C.  $100 \text{ m s}^{-1}$

D.  $200 \text{ m s}^{-1}$

16. If a trader made a profit of 10 % in selling a shirt for GH¢ 44.00, find the cost price.

A. GH¢ 38.50

B. GH¢ 39.60

C. GH¢ 40.00

D. GH¢ 48.40

17. If  $\mathbf{a} = \begin{pmatrix} 2 \\ -3 \end{pmatrix}$  and  $\mathbf{b} = \begin{pmatrix} -2 \\ 3 \end{pmatrix}$ , find  $\mathbf{a} + \mathbf{b}$ .

A.  $\begin{pmatrix} 4 \\ 0 \end{pmatrix}$

B.  $\begin{pmatrix} 2 \\ 3 \end{pmatrix}$

C.  $\begin{pmatrix} 0 \\ 0 \end{pmatrix}$

D.  $\begin{pmatrix} -0 \\ 6 \end{pmatrix}$

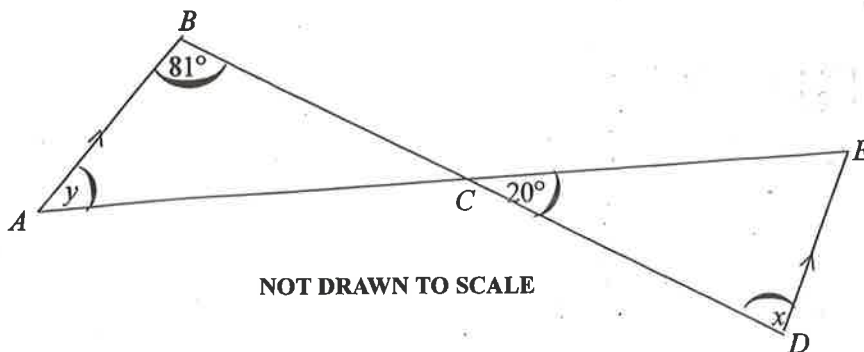

In the diagram,  $AB$  is parallel to  $DE$ , angle  $ABC = 81^\circ$  and angle  $DCE = 20^\circ$ .  
Use the information to answer questions 18 and 19.

18. Find the value of  $y$ .
- $20^\circ$
  - $79^\circ$
  - $81^\circ$
  - $101^\circ$
19. What is the value of  $x$ ?
- $81^\circ$
  - $61^\circ$
  - $20^\circ$
  - $101^\circ$
20. Peter had GH¢ 200.00 and spent GH¢ 83.00. What percentage of the money is left?
- 70.94 %
  - 58.50 %
  - 41.50 %
  - 29.06 %
21. Given that  $P(3, -2)$  and  $Q(-2, 4)$  are points in a plane, find the gradient of the line joining  $P$  to  $Q$ .
- $-\frac{6}{5}$
  - $-\frac{5}{6}$
  - $\frac{5}{6}$
  - $\frac{6}{5}$

22. Given that  $\vec{PQ} = \begin{pmatrix} -3 \\ 8 \end{pmatrix}$ , find  $\vec{QP}$ .

A.  $\begin{pmatrix} -3 \\ 8 \end{pmatrix}$

B.  $\begin{pmatrix} 8 \\ -3 \end{pmatrix}$

C.  $\begin{pmatrix} -3 \\ -8 \end{pmatrix}$

D.  $\begin{pmatrix} 3 \\ -8 \end{pmatrix}$

23. Given that  $117(12 + 18) = 117(15 + k)$ , find the value of  $k$ .

A. -30

B. -15

C. 15

D. 30

The stem and leaf plot shows the weights (kg) of cocoa bags weighed in a week.  
Use the information to answer questions 24 to 26.

Stem	Leaf
4	0, 5, 7, 9
5	1, 3, 4, 5, 7, 8
6	0, 2, 3, 4, 4, 4, 4, 5, 6, 8
7	1, 2, 3, 4, 5, 8, 8, 9
8	2, 3, 5, 6, 9
9	4, 5

24. How many bags of cocoa were weighed in the week?

A. 6

B. 29

C. 35

D. 41

25. What is the modal weight of the bags of cocoa?

A. 60 kg

B. 64 kg

C. 65 kg

D. 68 kg

**Turn over**

26. What is the median weight of the bags of cocoa?

- A. 61 kg
- B. 62 kg
- C. 65 kg
- D. 68 kg

27. A certain number is subtracted from 12 and the result is multiplied by 3. If the answer is 21, find the number.

- A. 4
- B. 5
- C. 6
- D. 8

28. Simplify  $1\frac{1}{5} \div 2\frac{1}{10}$ .

- A.  $\frac{4}{7}$
- B.  $\frac{25}{63}$
- C.  $\frac{12}{63}$
- D.  $2\frac{13}{25}$

29. If  $\frac{n}{100} = 10.5$ , find the value of  $n$ .

- A. 0.0105
- B. 0.105
- C. 105
- D. 1050

30. Express 108 as a product of prime factors.

- A.  $2^2 \times 3^3$
- B.  $2^3 \times 3^2$
- C.  $2 \times 3^4$
- D.  $2^3 \times 3$

31. The ratio of farmers to children in a village is 13 : 11. If there were 312 farmers in the village, how many children were there?
- A. 48
  - B. 143
  - C. 169
  - D. 264
32. The **longest** chord of a circle is the
- A. circumference.
  - B. diameter.
  - C. sector.
  - D. segment.
33. The point  $S(4, 3)$  is reflected in the  $y$ -axis. Find the coordinates of the image of  $S$ .
- A.  $(-3, 4)$
  - B.  $(3, -4)$
  - C.  $(-4, 3)$
  - D.  $(4, -3)$
34. The rule of a mapping is  $x \rightarrow 2x^2 - 1$ . What number does  $x = 2$  map to?
- A. 3
  - B. 7
  - C. 8
  - D. 9
35. Express 15 : 12 in the form 1 :  $n$ .
- A. 1 : 0.8
  - B. 1 : 1.2
  - C. 1 : 15
  - D. 1 : 12

36. A shop is rented at GH¢ 9.00 per month. How much money is paid in  $1\frac{1}{2}$  years?
- A. GH¢ 6.00  
B. GH¢ 13.50  
C. GH¢ 135.00  
D. GH¢ 162.00
37. Arrange the following fractions from the lowest to the highest:  $\frac{3}{5}, \frac{1}{4}, \frac{2}{3}$ .
- A.  $\frac{3}{5}, \frac{1}{4}, \frac{2}{3}$   
B.  $\frac{1}{4}, \frac{3}{5}, \frac{2}{3}$   
C.  $\frac{2}{3}, \frac{1}{4}, \frac{3}{5}$   
D.  $\frac{2}{3}, \frac{3}{5}, \frac{1}{4}$
38. Simplify:  $-15 - (-20) + (-10)$ .
- A. -45  
B. -25  
C. -5  
D. 5
39. What is the probability that a number greater than 5 shows up when a die is thrown?
- A.  $\frac{1}{6}$   
B.  $\frac{1}{3}$   
C.  $\frac{2}{3}$   
D.  $\frac{5}{6}$
40. For what value of  $x$  is  $3^x = 81$ ?
- A. 2  
B. 4  
C. 9  
D. 27

**END OF PAPER**